

Anzahl:	1 Stk.
Material:	S235/1.4301
Oberfläche:	
Massstab:	1:2.5/1:20/1:10
<small>Diese Zeichnung ist Eigentum der AMBOSS Metallbau AG. Sie darf ohne unsere Einwilligung weder kopiert, weitergeleitet, noch zur Ausführung benutzt werden.</small>	
AMBOSS Metallbau AG Industriestr. 1 6345 Neuheim 041 530 71 30 info@amboss-ag.ch	

geländerXpress.ch Übersicht Staketengeländer Flex		
Detail		
Projekt-Nr.	Zeichnungs-Nr.	Rev.:
	14000 - A01 -	

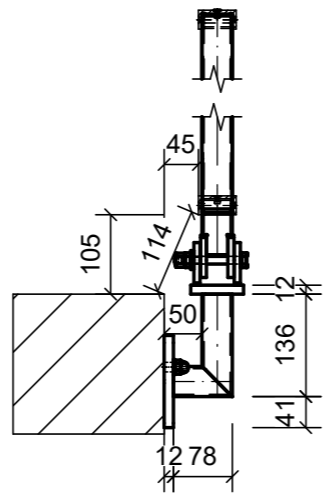

Klemmteil (2 pro Geländer)
Blech 12 1.4301

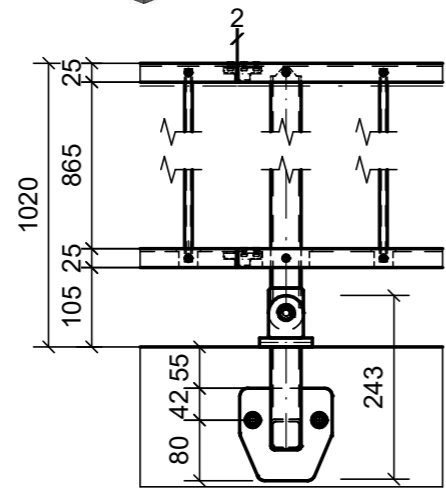
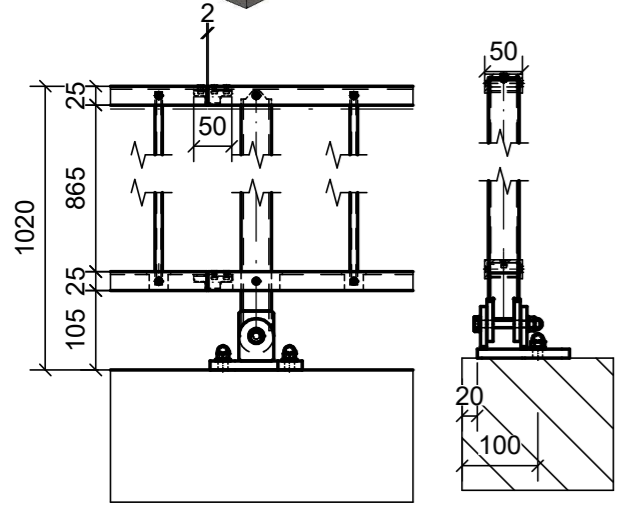
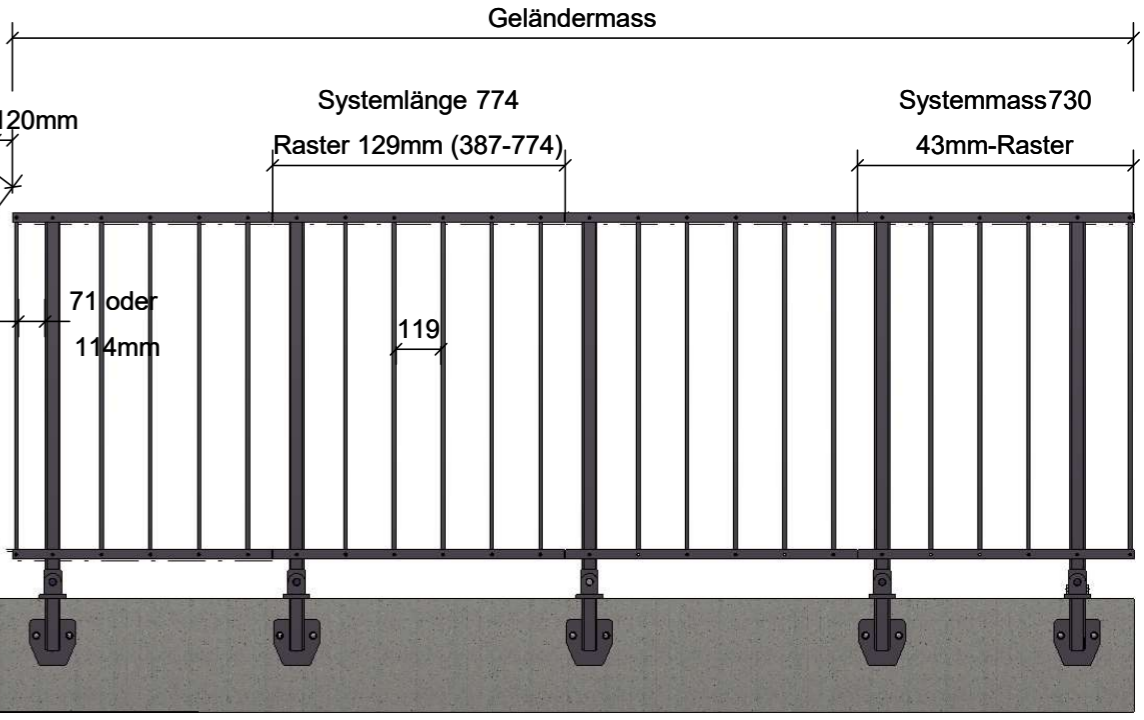
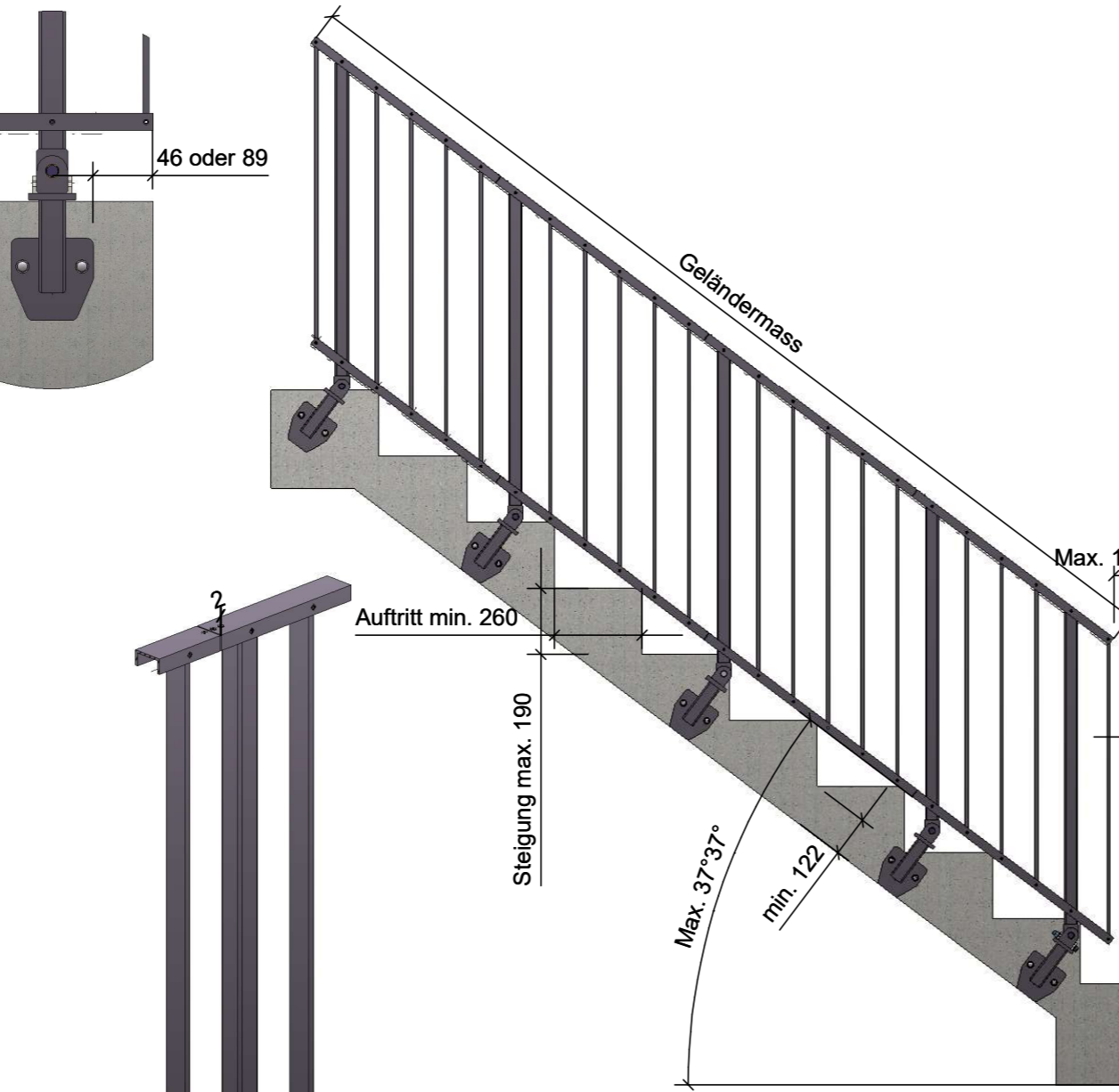
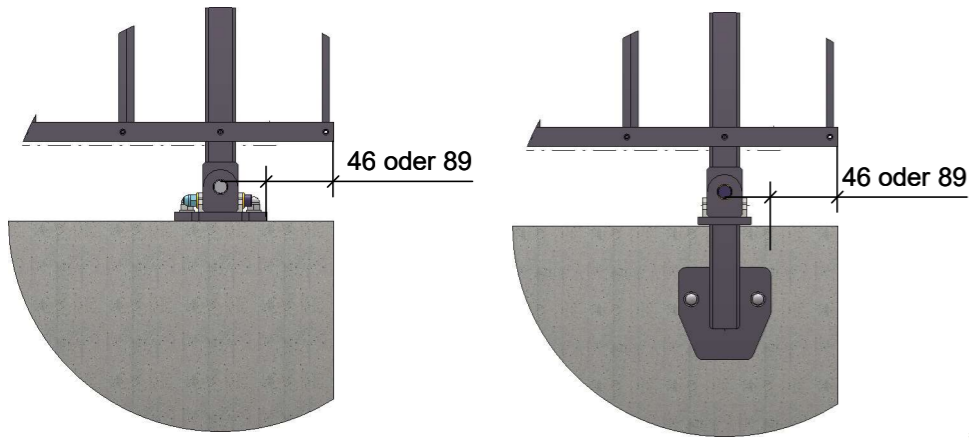
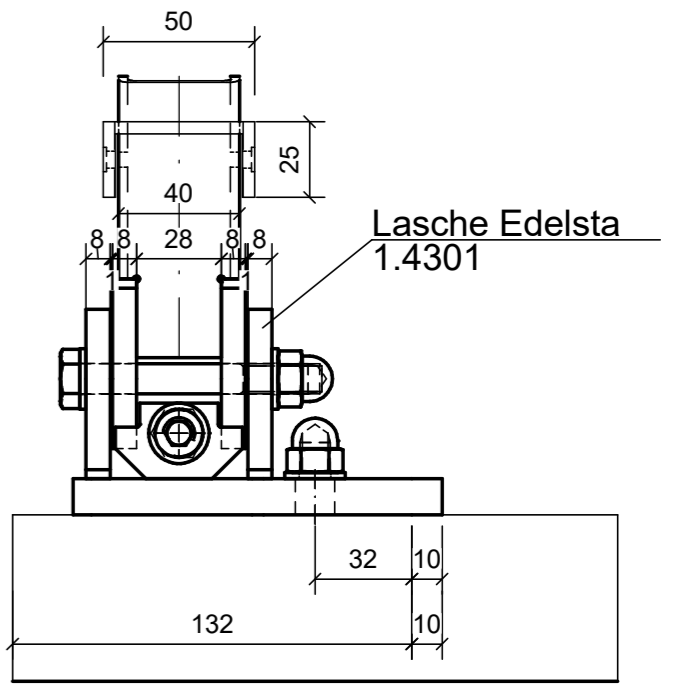
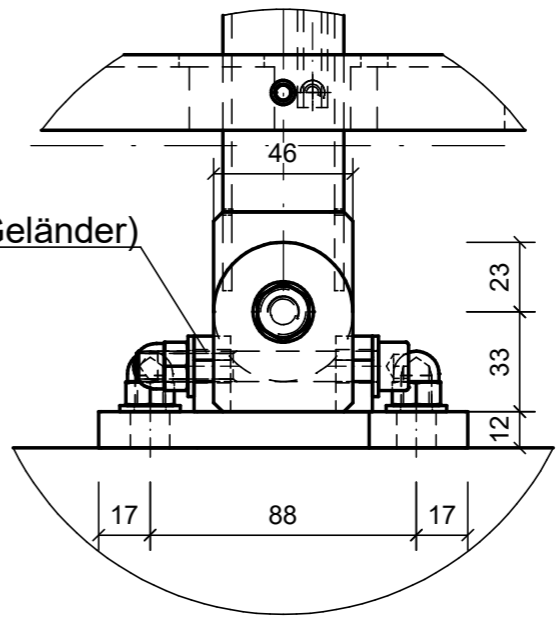

Lasche Edelsta
1.4301